

Product Datasheet



The global certified BLD-320-C is a dual stage extremely wide input smart LED driver with **independent multi-channel** outputs. 10kV surge protection level, 100khour long life and 7-year warranty provide high confidence to luminaire users. All around protections with auto-recovery secure 24hour non-stop operation for luminaires.

- Stadium
- Flood
- Harbor

- Features 2
- Model List 2
- Technical Data 3
- Safety/EMC Compliance 4
- Dimming 5
- Programming 6
- Lifetime vs. Case Temperature 7
- Power Factor vs. Load 7
- THD vs. Load 8
- Efficiency vs. Load 8
- Inrush Current 9
- Dielectric Strength 9
- Tc Point 10
- Packaging Information 10
- Mechanical Design 11
- Output Operation Range 13
- Revision History 14

320W, 120-277Vac Input, RGBW Quad Output LED Driver

■ Features

- Absolute Supply Voltage: 108~305Vac
- Great Surge Immunity 10kV
- 93% Efficiency Max.
- Low Inrush Current
- 100,000Hour Life @ Tc=75°C
- 7 Year Warranty @ Tc<=75°C
- Output Current Programmability
- Live Broadcasting Level Low Ripple
- DMX/RDM/DALI2.0 Dimmable with Independent Control
- Fast Dynamic Response
- DALI Part 150, 250 Support
- DALI Type 6 (SimplySnap Compatible)
- IP67/IP66 Rated Waterproof
- UL Class 2 Output
- Safety according to UL8750, EN 61347-1, 61347-2-13, 62384

■ Model List

Model Number	Input Voltage Range	Output Power	Output Voltage	Full Power Settable Current Min	Full Power Settable Current Max	Certification
BLD-320-C800-XYZ-NNNNS4	108~305Vac	P1: 80W	24-53Vdc	1.5A	2A	FCC/CE
		P2: 80W				
		P3: 80W				
		P4: 80W				
BLD-320-C320-XYZ-NNNNS4	108~305Vac	P1: 80W	60-160Vdc	0.5A	0.8A	FCC/CE
		P2: 80W				
		P3: 80W				
		P4: 80W				
XY=	Dimming Method	Programmable	Vaux	Dim-off		
AN	DALI2.0	Cable	24V 150mA	√		
MN	DMX512 + RDM	Cable	-	√		
Z=	U	V	S	W	D	
Input Cable	3 pin UL cable with ground	3 pin UL cable with ground	3 pin VDE cable with ground	3 pin VDE cable with ground	2 pin VDE cable without ground	
Output Cable	5 pin UL cable without Ground	6 pin UL cable with ground	5 pin VDE cable without ground	6 pin VDE cable with ground	5 pin VDE cable without ground	
Certified Input Voltage Range	120-277Vac	120-277Vac	Class I 120-277Vac	Class I 120-277Vac	Class II 120-277Vac	

■ Technical Data

Input Voltage	108~305Vac
Input Frequency	47~63Hz
Power Factor	>0.9@60-100%load, refer to PF vs. Load curve
THD	<15%@60-100%load, refer to THD vs. Load curve
Input Current	3.0Amax@120Vac & Full-Load, 1.6Amax@220Vac & Full-Load
Inrush Current	See Inrush Current Section in the datasheet
Leakage Current	0.75MIU max @277Vac 60Hz, UL8750 0.7mA max @240Vac 50/60Hz, IEC60598-1
Input Under Voltage	Shut down and auto-restart
Surge Protection	Line to line 6kV, line to ground 10kV, IEC 61000-4-5
Current Accuracy	±2%lo
Ripple Current	lpk-pk: low frequency (<=3kHz) 2%lo max, high frequency (>3kHz) 15%lo max
TLA (Temporal Light Artifacts)	PstLM<0.02, SVM<0.05
Percent Flicker	1% max. Broadcasting level, GB/T-38539-2020
Setup Time	1.2s max
Overshoot	10% lo max & LED Load
Output Over Voltage	120% Vomax, typ.
Short Circuit	Auto recovery. The output recovers when short is removed.
Over Temperature	Lower the output current when $T_c \geq 105 \pm 10^\circ\text{C}$; Auto Recovery When $T_c \leq 70 \pm 10^\circ\text{C}$
Operating Temperature	Case Temperature $T_c = -40^\circ\text{C} \sim +90^\circ\text{C}$; 10%RH ~ 100%RH
Storage Temperature	$-40^\circ\text{C} \sim +85^\circ\text{C}$; 5%RH ~ 100%RH
MTBF	$\geq 320,000$ hours, 75°C case temperature (MIL-HDBK-217F)
Lifetime	$\geq 100,000$ hours, 75°C case temperature, refer to life vs. T_c curve
Case Temperature	90°C max, marked in the T_c point of label
Dimension	309x 90 x 41.5 by mm (body), 336 x 90 x 41.5 by mm (endcaps included)
Net Weight	2000g
Packing	See Package Information Section in the datasheet

Notes: Unless specified, all the test results are measured in 25°C room temperature.

■ Safety/EMC Compliance

Safety Standard	Description
UL8750	Light emitting diode(LED) equipment for use in lighting products
UL1012	Power units other than class 2
IEC 61347-1	Lamp control gear Part 1: general and safety requirements
IEC 61347-2-13	Lamp control gear Part 2-13: particular requirement for d.c. or a.c. supplied electronic control gear for LED modules
EMI Standards	Description
IEC 55015	Conducted emission test & radiated emission test
IEC 61000-3-2	Harmonic current emissions; Class C
IEC 61000-3-3	Voltage fluctuations & flicker
FCC Part 15	ANSI C63.4:2009 Class B
EMS Standards	Description
IEC 61000-4-2	Electrostatic discharge (ESD): 8 kV air discharge, 4 kV contact discharge
IEC 61000-4-3	Radio frequency electromagnetic field susceptibility test (RS)
IEC 61000-4-4	Electrical fast transient (EFT)
IEC 61000-4-5	Surge immunity test
IEC 61000-4-6	Conducted radio frequency disturbances test (CS)
IEC 61000-4-8	Power frequency magnetic field test
IEC 61000-4-11	Voltage dips
IEC 61547	Electromagnetic immunity requirements applies to lighting equipment

■ Dimming

DALI Interface Standard	IEC62386, part 101,102,207,150,250		
DA1,DA2 High Level	9.5	16	22.5
DA1,DA2 Low Level	-6.5	0	6.5
DA1,DA2 Current	0		2mA
Default Memory Bank 1 CCT Value (Address 0x22 Definition)	CH1: Red, 0x01, CH2: Green, 0x02, CH3: Blue, 0x03, CH4: White, 0x05 (SimplySnap Compatible)		
DMX+ & DMX- Voltage	-6V		6V
DMX to Ground Resistance	25Mohm		
Logic 0/1 (DMX+ to DMX-) Threshold		0.2V	
Communication Baud Rate		250kbps	
Fast Dimming On-Off Transition		50ms	
Fast Dimming 10-100% Io Transition		30ms	
Flashing Speed	-	-	44fps

- DALI and DMX dimming curves

DALI Dimming Curve

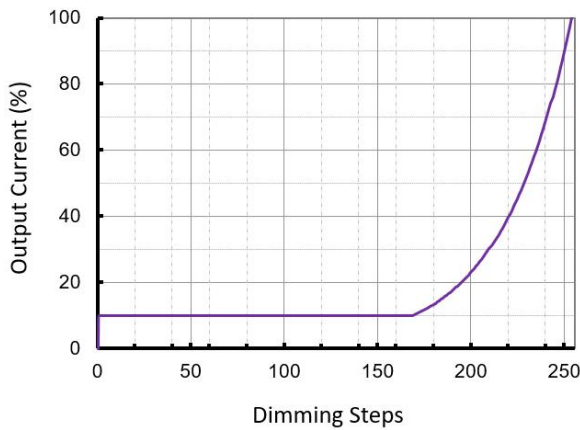

DMX/RDM Dimming Curve

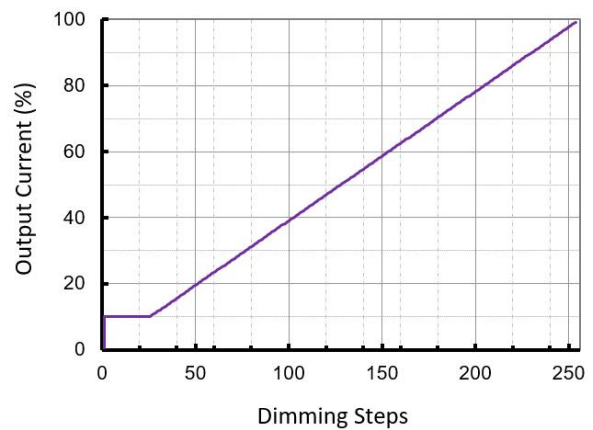

Note: Both DALI and DMX dimming curves can be customized to be linear or logarithmic as default.

■ Programming

- Programmable Functions

uPowerTek LED drivers offer a range of configurable functions to meet specific lighting requirements. The Output Current, Dimming Mode and DMX addressing can be set as basic programming functions. .

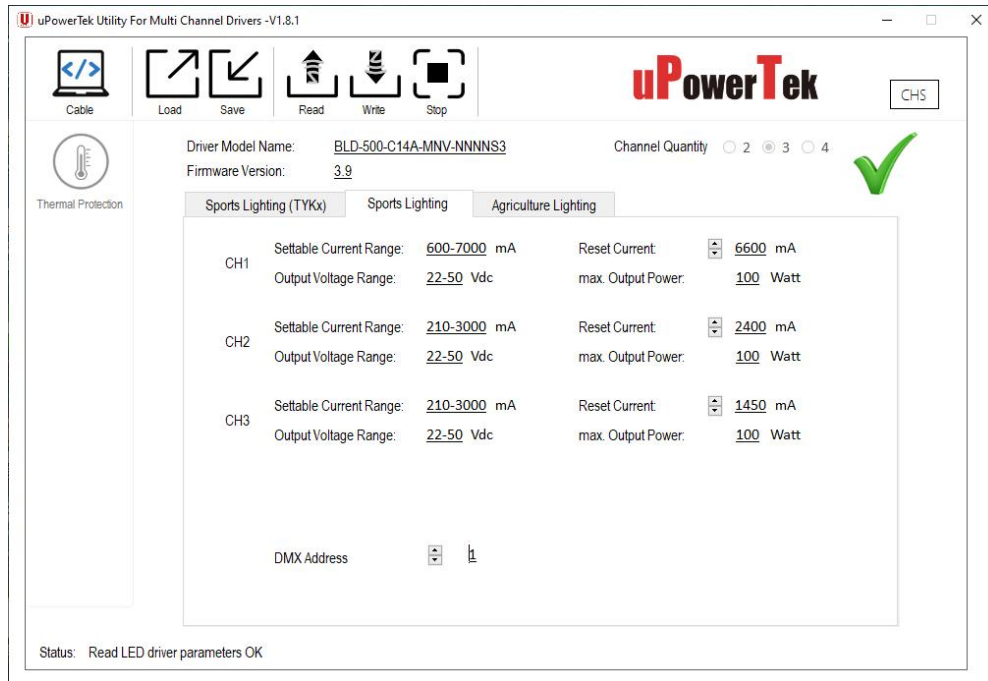

uPowreTek Programming Software Interface

- Connection Guide

This guide provides simple connection diagrams to help users understand the programming system. For more detailed operating instructions, including step-by-step procedures and additional configurations, please visit our website. You can download the comprehensive user manual and necessary software from the following link:

<https://www.upowertek.com/download-2/>.

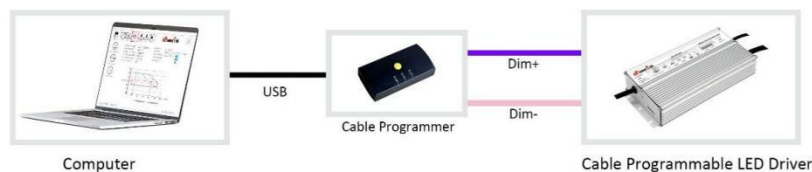

■ Lifetime vs. Case Temperature

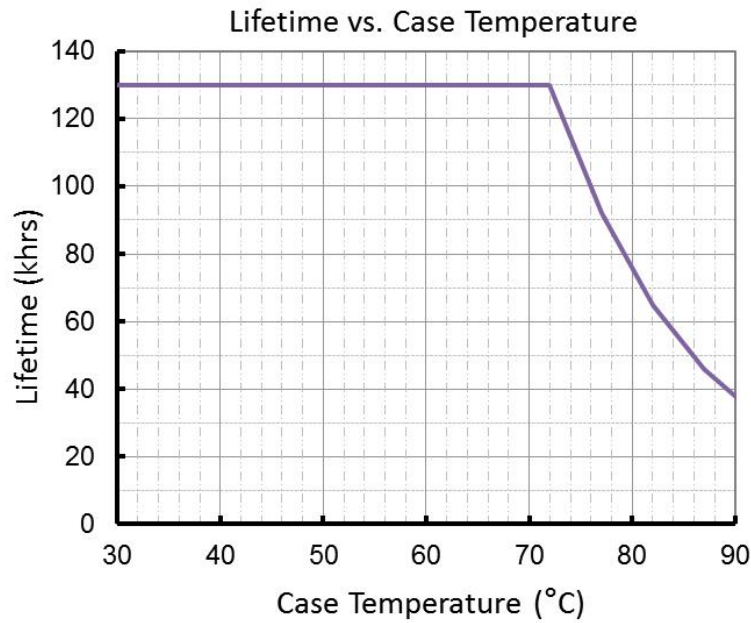

(End of Life: Maximum Failure Rate=10%)

■ Power Factor vs. Load

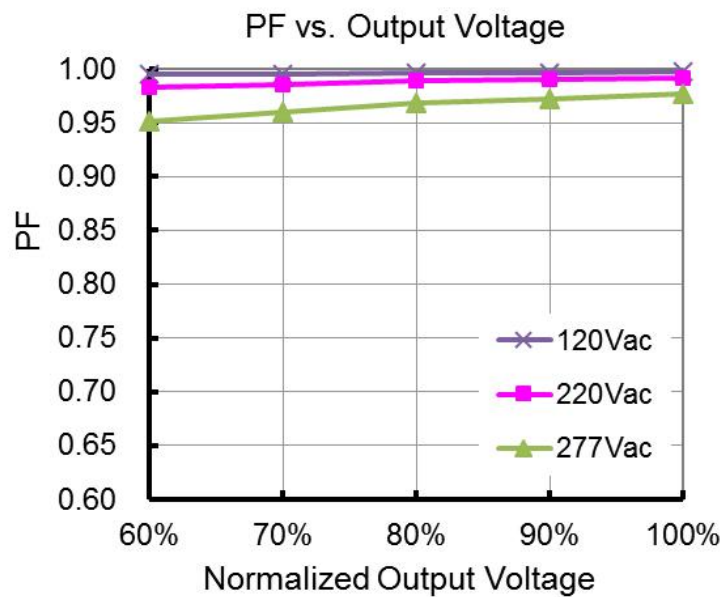

THD vs. Load

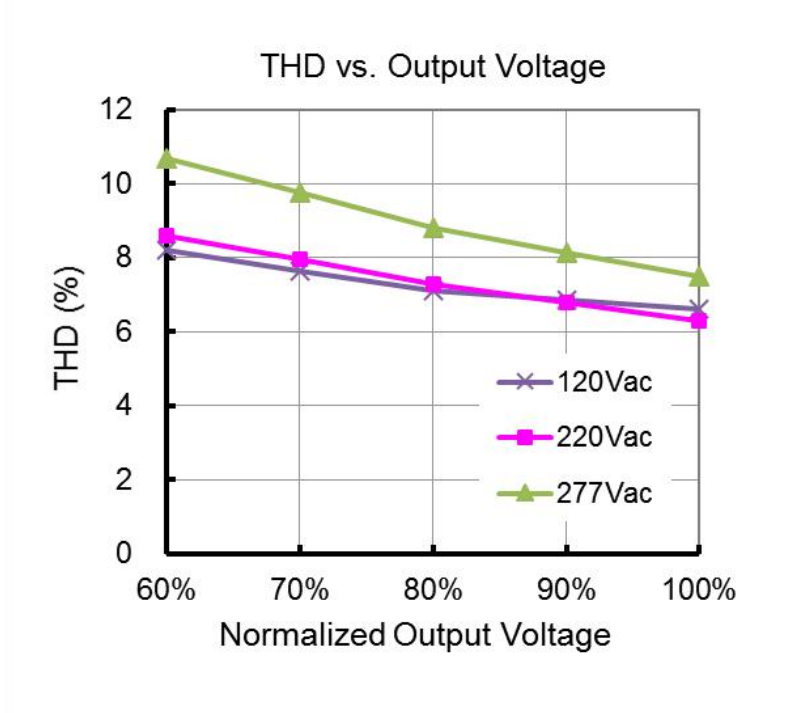

Efficiency vs. Load

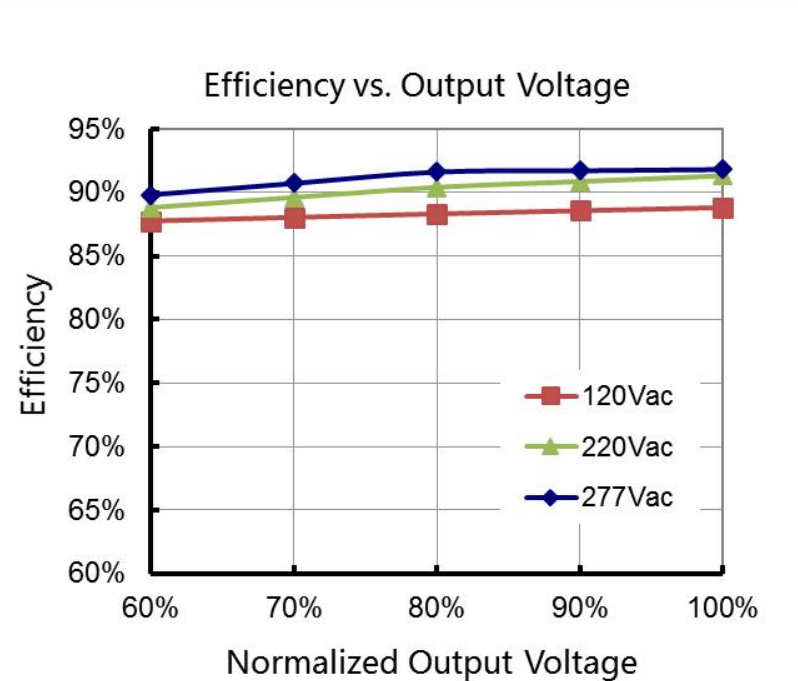

Inrush Current

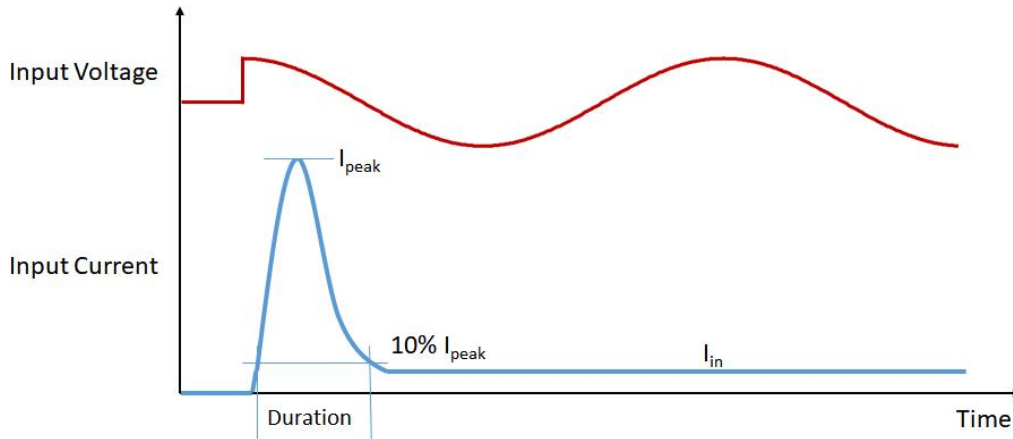

Input Voltage	I_{peak}	Duration
120Vac	18.0A	5.32mS
220Vac	30.8A	5.24mS
277Vac	42.2A	5.08mS

- MCB Suggestion

Type	B10	B16	B25	B32	C10	C16	C25	C32	D10	D16	D25	D32
Driver Quantity	1	2	4	5	2	4	7	9	5	8	12	16

Note: Calculated with MCB S200 series manufactured by ABB at 220Vac Input condition

Dielectric Strength

Unit: Vac	Input	Output	Dimming	Case
Input	-	3750	3750	1554
Output	3750	-	1554	1554
Dimming	3750	1554	-	1554
Case	1554	1554	1554	-

■ Tc Point

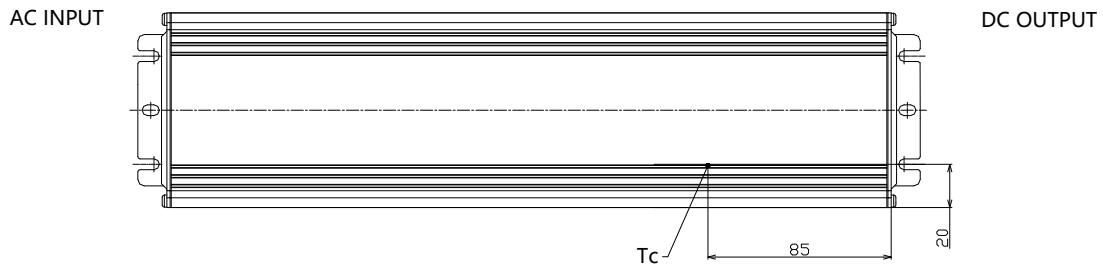

■ Packaging Information

Typical Carton Dimension(L×W×H)	490×370×125 mm
Positioning plate	2pcs/carton
Shield Board	1pcs/carton
LED Drivers/LED	6pcs/carton
Net Weight	12.0 kg/carton
Gross Weight	12.9 kg/carton

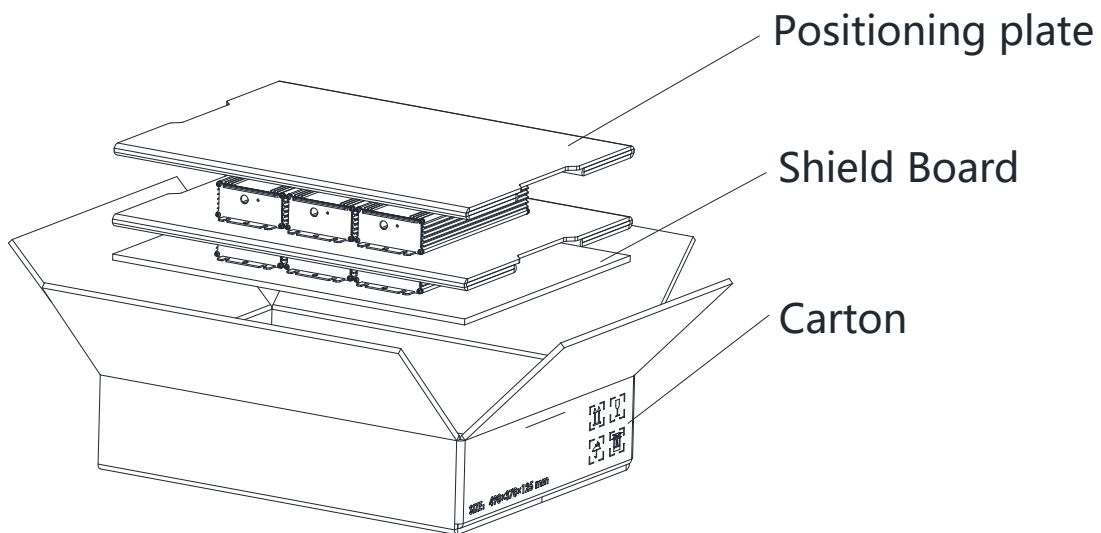

Mechanical Design

- BLD-320-Cxxx-ANU-NNNS4

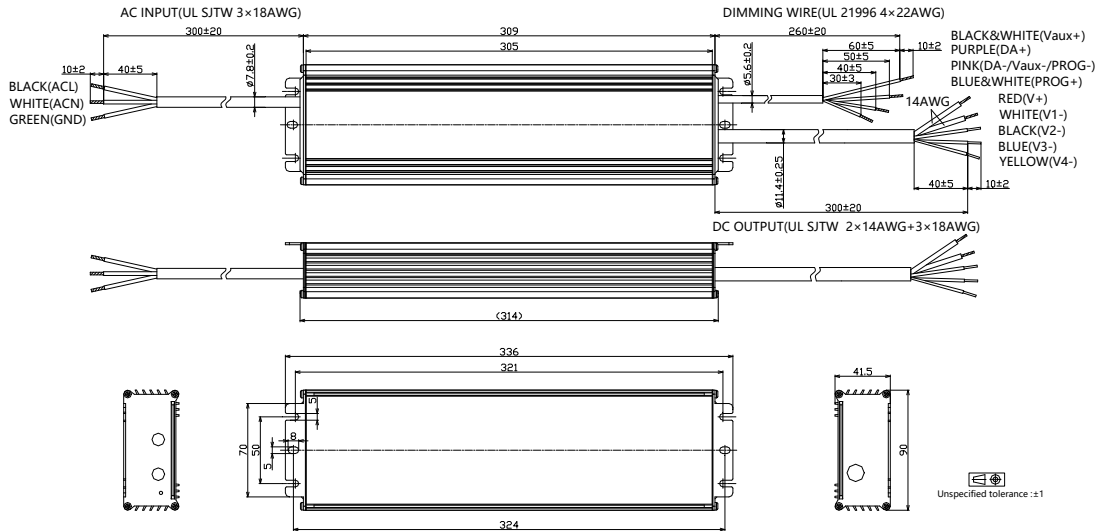

- BLD-320-Cxxx-MNU-NNNS4

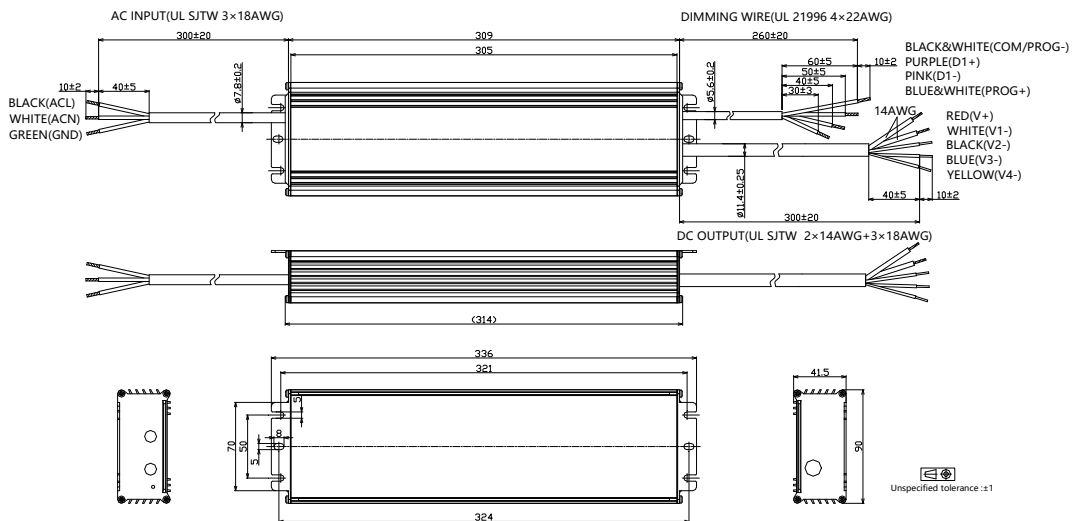

320W, 120-277Vac Input, RGBW Quad Output LED Driver

- BLD-320-Cxxx-ANS-NNNNS4

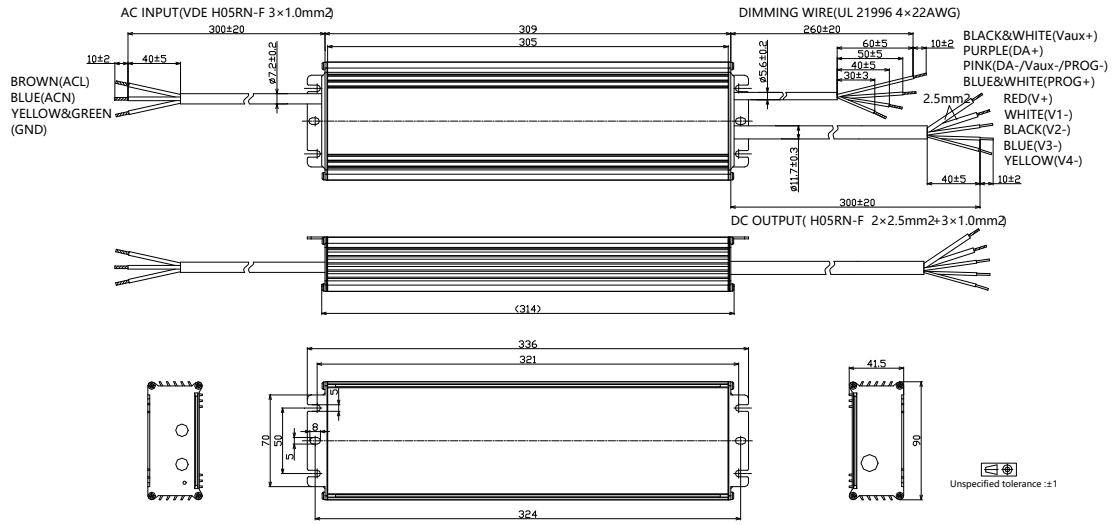

- BLD-320-Cxxx-MNS-NNNNS4

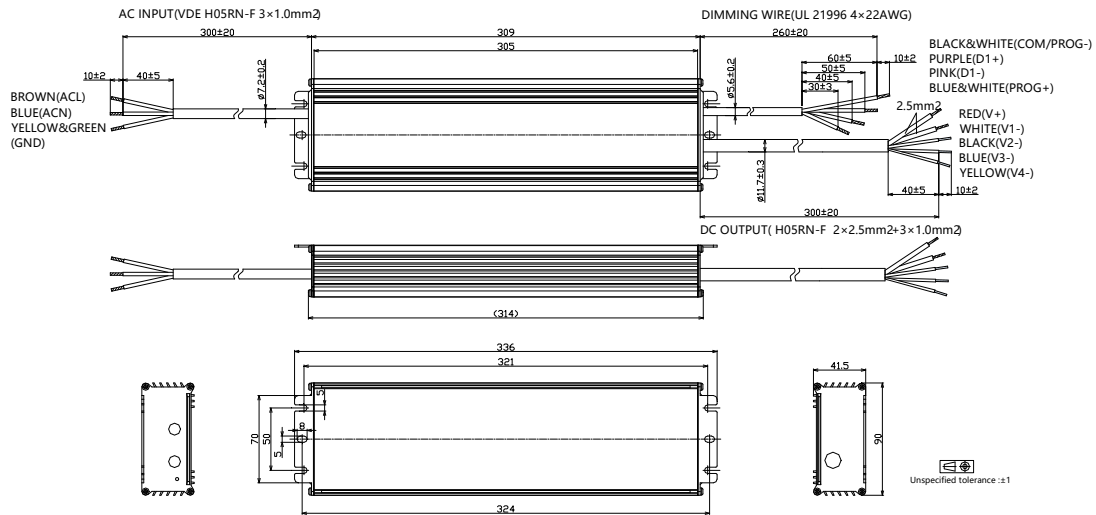

■ Output Operation Range

Model	Typical Set Output Current (mA)	Max Output Power (W)	Output Voltage Min (V)	Output Voltage Max(V)	Minimum Dimming Current (mA)
C320	800	320/80	60	100	80
	750	320/80	64	107	75
	700	320/80	69	114	70
	650	320/80	74	123	65
	600	320/80	80	133	60
	550	320/80	87	145	55
	500	320/80	96	160	50
	450	288/72	96	160	50
	400	256/64	96	160	50
	350	224/56	96	160	50

	50	32/8	96	160	50

Model	Typical Set Output Current (mA)	Max Output Power (W)	Output Voltage Min (V)	Output Voltage Max(V)	Minimum Dimming Current (mA)
C800	2000	320/80	24	40	200
	1900	320/80	25	42	190
	1800	320/80	27	44	180
	1700	320/80	28	47	170
	1600	320/80	30	50	160
	1500	320/80	32	53	150
	1400	300/75	32	53	150
	1300	276/69	32	53	150
	1200	256/64	32	53	150

	150	212/53	32	53	150

■ Revision History

Revision	Date	Contents
0.1	2024-04-25	Initial
0.2	2024-11-16	1. DALI memory bank 1 definition for RGB(W) application